

Parameters for Crystal Growth of Ribosomal Subunits

A. Yonath, J. Müssig, and H.G. Wittmann

Department of Structural Chemistry, Weizmann Institute of Science, Rehovot, Israel (A.Y.), and Max-Planck-Institut für Molekulare Genetik, D-1000 Berlin (Dahlem), Federal Republic of Germany (J.M., H.G.W.)

A systematic analysis of the parameters that control the crystal growth of the large subunit of ribosomes from *B. stearothermophilus* has been carried out. Several parameters have been identified and classified according to their significance. It was found that only biologically active particles can crystallize and that the critical period for the crystallization process is the first few days, during which changes in the volume and content of the crystallization drop are of importance for both nucleation and crystal growth. Consequently, an experimental procedure for fine control of these variables has been developed. As a result of these studies, the reproducibility of crystal formation was increased, and larger and more stable crystals have been obtained.

Key words: ribosomes, *Bacillus*, crystallization, electron microscopy, X-ray diffraction

Ribosomes play a central role in protein biosynthesis. Therefore numerous studies have attempted to elucidate their structure (for recent reviews see [1-4]). All 53 proteins of the *E. coli* ribosomes have been isolated and characterized, and their sequences [4], as well as those of the three rRNAs [5] are now known. Several techniques, such as immune electron microscopy [6,7], neutron scattering [8], chemical crosslinking [9], fluorescence spectroscopy [10], and reconstitution [11,12], give valuable but as yet insufficient information about the shape and the inner structure of the ribosomal particles.

X-ray crystallography, which is the most powerful method for construction of molecular models requires large crystals. Three-dimensional structure determination of macromolecules has recently advanced rapidly, especially in the effectiveness in collecting, processing, and analyzing crystallographic data. Consequently, the structures of some large molecular assemblies [13-16] have been determined. Yet, the first step for crystallographic studies, that of obtaining suitable crystals, is still unpredictable and often very difficult, even for relatively small biological macromolecules. This stems from the intricate nature of the crystallization process and the time and labor required to carry out a systematic survey of all the parameters that are involved in crystallization.

Received January 4, 1982; accepted February 3, 1982.

Large crystalline sheets have been obtained *in vivo* from ribosomes from various sources, such as lizards [17], chick embryos [18], and the brain of senile humans [19]. Also, helical and two-dimensional arrays of the *E. coli* ribosomal subunits have recently been obtained [7]. However, *in vitro* crystallization of ribosomes and ribosomal subunits has proved to be most difficult, perhaps due to their enormous size and their asymmetrical internal organization.

Initially, microcrystals of the large ribosomal subunit from *B. stearothermophilus* were obtained, using the vapour diffusion method in the hanging drop system with organic solvents as precipitants. The ribosomal particles in the crystalline form maintained their biological activity and comigrated with standard 50S particles in a sucrose gradient [20]. The prospect for subsequent structural studies seemed promising, since X-ray powder patterns of these crystals contained features between 30 nm and 0.35 nm, and the crystals proved suitable for three-dimensional image reconstruction studies [21]. To promote the feasibility of structural analysis, we analyzed the parameters that led to crystal production and tried to deduce practical guidelines for both increasing the reproducibility of crystal growth and obtaining larger and more stable crystals.

As will be described in this paper, several parameters of this system have been identified and characterized according to their significance. It was shown that starting from biologically active particles is essential, that one of the important factors for nucleation and for subsequent crystal growth is related to the early period of crystallization, and that there are specific geometrical and kinetic requirements that should be met during crystallization. Consequently, we developed an experimental procedure for fine monitoring of the content of the crystallization medium. In view of the effectiveness and the simplicity of this procedure, we hope that it will be useful for crystallization of other complicated biological assemblies.

MATERIALS

Ribosomal subunits of *B. stearothermophilus* (strain 799) were obtained as described [20]. The isolated ribosomal subunits were stored at a concentration higher than 200 A_{260} units per milliliter in TMA-I buffer (10 mM Tris-HCl (pH 7.6 at 25°C), 30 mM NH_4Cl , 10 mM $MgCl_2$, 6 mM β -mercaptoethanol) at $-80^\circ C$. Shortly before the crystallization experiment the stored subunits were further dialysed against either TMA-I or H-I (10 mM HEPES (pH = 7.6 at 25°C), 60 mM NH_4Cl , 10 mM $MgCl_2$, 6 mM β -mercaptoethanol) buffers and centrifuged in a Sorvall SS-34 rotor at 10,000 rpm for 20 min.

Chemicals

The reagents used were the purest commercially available. All the solutions (including the buffers) were ultrafiltered (Millipore) prior to crystallization. Stock solutions were kept at $-20^\circ C$ for no longer than two months. The following organic solvents (or a combination of them) were used as crystallization agents: methanol, ethanol, iso-propanol, *tert*-butanol, *n*-butanol, 2-methyl-2,4-pentadiol (MPD), which was further purified by distillation, 2-ethyl-1,3-hexanediol (EHD), 2-ethyl-1-butanol (EB) redistilled, ethanediol (ED), glycerol, toluene, acetone, 1,4-dioxane, and chloroform. Control experiments were carried out with inorganic salts (eg, potassium nitrate) and proteins (eg, soybean agglutinin (SBA), which was kindly supplied by Dr. N. Sharon, Weizmann Institute, Rehovot).

METHODS

Crystallization

The "conventional" vapor-diffusion technique [22-24] was employed with some modifications. Three different systems were assembled: (1) hanging drops on glass plates (Fig. 1); (2) liquid column in X-ray capillaries (Fig. 2); (3) multiple depression plates (Fig. 3). All the crystallizing media contained the ribosomal subunits and a buffer for controlling the pH. No organic solvent was added to the solution of the subunits prior to the crystallization. The contents of the different reservoirs are given below. Glass, rather than plastic, was used to avoid interactions with the organic solvents. All the glassware that was to be in touch with the crystallizing subunits was cleaned, dipped in silicon solution (Serva, Heidelberg), and heated for 1 hour at 100°C. Air-tight sealing was achieved by evenly spreading high vacuum grease (N.V. Dow Corning S.A., Belgium) on the previously ground rims of the containers.

The variables for the crystallization survey were the precipitant, the pH (4.5-10.0), reservoir content (see below), subunit concentration (8-24 mg/ml), the buffers in which the subunits were stored (TMA-I or H-I), the addition of several components (Mg^{2+} , spermidine) to the crystallizing mixture, and the particular system used for crystallizing. The concentration of the precipitant in the reservoir was increased if no crystals appeared within the first three weeks, and was decreased only if an unordered precipitate had formed. All crystallization experiments were carried out at 3-7°C.

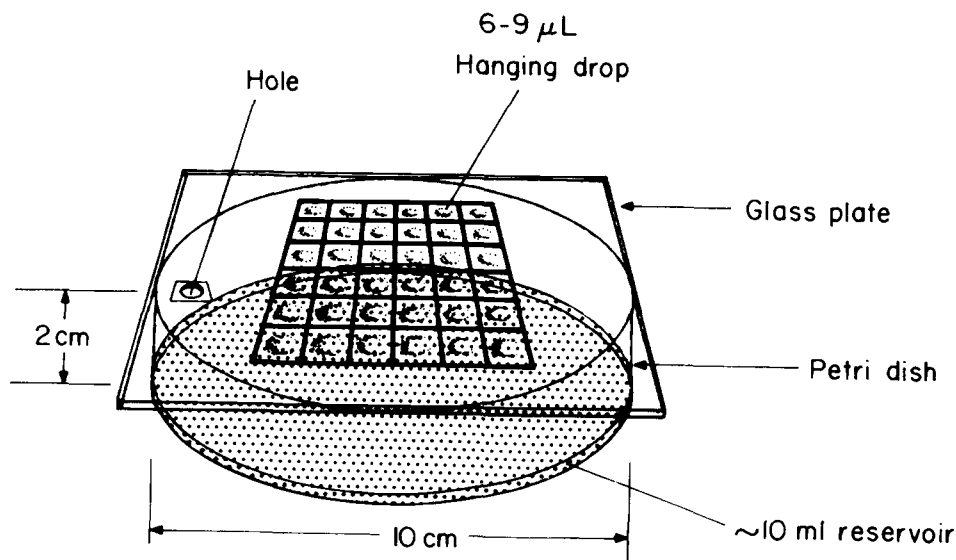

Fig. 1. The crystallization system used for the hanging drop on glass plates.

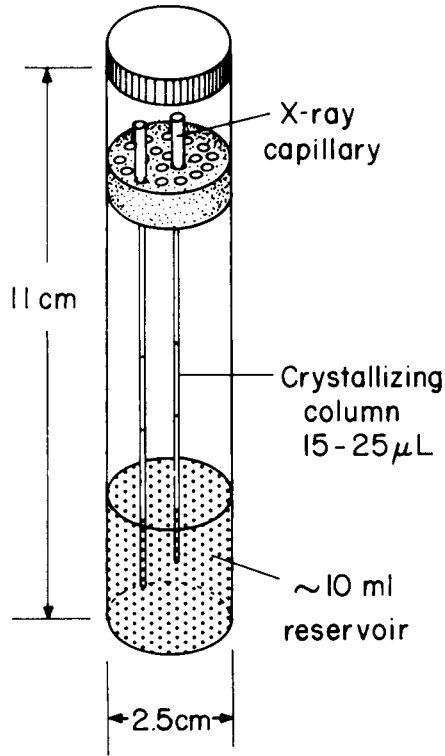

Fig. 2. The crystallization system used for vapor diffusion in capillaries.

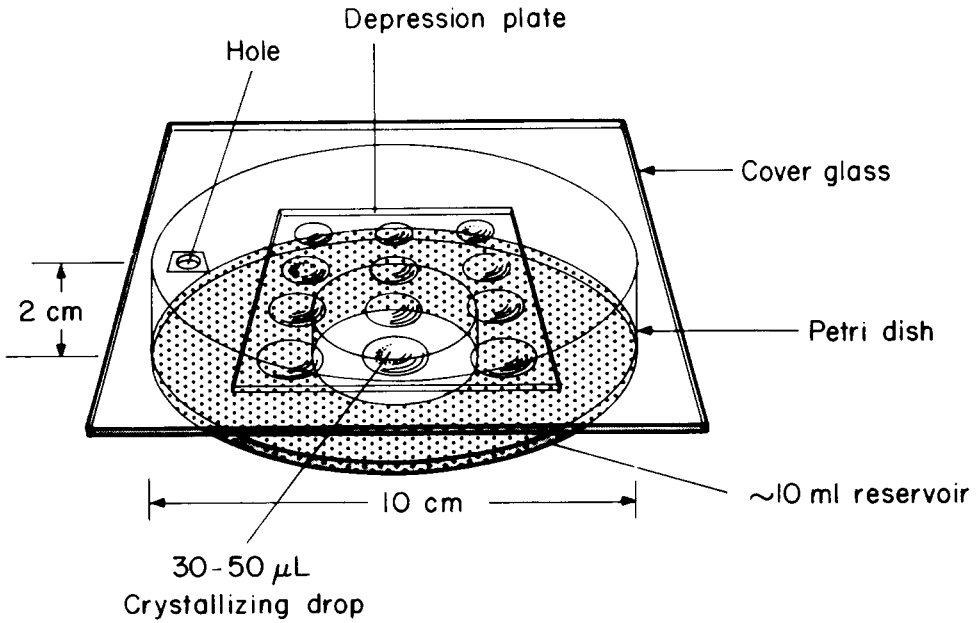

Fig. 3. The crystallization system used for vapor diffusion in depression plates.

Measurement of the Shape and the Volume of the Crystallizing Droplet

We concentrated only on drops that had the overall shape of a spherical segment. The radius of the segment (a) was measured directly from the scale on the microscope eyepiece. For measuring the depth of the droplet (h) the microscope was focused on the top and on the bottom of the droplet. The vertical distance between these two points was measured by the number of turns needed for this translation. The volume of the droplet was computed according to the formula $\text{Vol} = \pi h (h^2 + 3a^2)/6$.

The accuracy of these measurements was determined from a comparison of the known volumes of freshly prepared droplets and those calculated from their measured radii and heights (Table I).

X-ray Studies

X-ray patterns were recorded at 4–6°C, using a Supper camera on a Philips generator, equipped with a fine focus copper tube, operating at 1500 watts.

RESULTS AND DISCUSSION

Analysis of Crystal Growth

For the initial survey we employed the vapor–diffusion technique in Petri dishes (Fig. 1). This method is convenient for a multiparameter investigation since it requires little space. As many as 36 droplets could be placed on one glass plate, and the appropriate controls could be studied simultaneously with the actual crystallizing droplets. The system also permits continuous monitoring of crystal growth, as it is possible to change the content of the reservoir without disturbing the droplet or its geometry.

A strong correlation was found between the biological activity of the subunits and the production of crystals. Those preparations that had a low activity did not produce crystals at all. In contrast, more than 90% of the experiments with active preparations were successful to varying degrees. However, there is some variation in the exact conditions of the crystallization, and they need to be redefined for each preparation of subunits. Thus, although the overall tendency to crystallize is similar for most preparations, the growth rate, the size, and the quality of the crystals are somewhat different for still unknown reasons. These may be due to slight differences in bacterial growth, the isolation of the ribosomal subunits and/or their storage.

In almost every experiment that led to crystal growth, a fine precipitate was also formed. In the hanging drops the crystals were found close to the interface between the air and the droplet whereas the precipitate concentrated in its center. Most of the pre-

TABLE I. Calculated Volume of Fresh Droplets

Initial volume 7 μl			Initial volume 9 μl		
a (mm)	h (mm)	vol (μl)	a (mm)	h (mm)	vol (μl)
2.00	1.04	7.12	2.24	1.10	9.37
2.04	1.00	7.06	2.20	1.10	9.06
1.96	1.04	6.87	2.34	1.00	9.12
1.92	1.08	6.91	2.30	1.02	9.03
1.98	1.04	6.99	2.18	1.10	8.91

cipitate formed in capillaries sedimented to the bottom of the crystallizing column but a small amount was evenly distributed throughout the solution, together with the crystals.

The organic solvents are classified in two main groups: those whose vapor pressure is higher than that of water (volatile), and those whose vapor pressure is lower (less volatile). The first crystals were grown using a less volatile solvent (ED). It was found that for both groups there was no significant difference between the water-soluble and the insoluble solvents. The shape and volume of some crystallizing and control droplets have been measured. Several representative results are given in Table II. The spreading of all droplets that contained subunits was observed, accompanied by an increase in the volumes of the droplets, which were equilibrated with organic solvents. The expansion was larger when volatile solvents were used. In principle, volatile organic solvents should lead to an increase of the volume of the droplet, whereas the opposite effect is

TABLE II. Some Geometric Properties of Hanging Drops

Reservoir ^a	Drop ^b	Initial volume (μ l) ^c	After 12 weeks		Volume (μ l)
			Radius (mm)	Height (mm)	
(a) No salt in the reservoir					
12.5% dioxane	s.u.	7	3.24	0.54	8.99
	m.l.	7	1.90	1.20	7.71
12.2% EB	s.u.	9	3.45	0.54	10.24
	m.l.	9	1.00	0.80	1.53
9% ter-butanol	s.u.	9	3.45	0.57	11.01
	SBA	9	2.54	0.38	3.88
14% ED	s.u.	7	3.70	0.40	8.64
	m.l.	7	1.50	0.68	2.57
(b) With salt in the reservoir					
12.5% dioxane + 0.9M NaCl	s.u.	7	2.90	0.42	5.59
	m.l.	7	1.18	0.68	1.65
12% EB + 0.8 M NaCl	s.u.	9	3.15	0.42	6.63
	m.l.	7	1.00	0.64	1.14
12% ter-butanol + 0.6 M NaCl	s.u.	9	3.09	0.50	7.61
	SBA	9	1.20	0.66	1.54
14% ED + 0.8 M NaCl	s.u.	7	2.60	0.56	6.04
	SBA	9	2.62	0.38	4.13
(c) Inorganic salts					
1 M KNO ₃	s.u.	7	2.54	0.36	3.67
	m.l.	7	1.12	0.66	1.45
	SBA	7	1.12	0.70	1.56

In all experiments the composition of the droplet was as follows: 15–20 mg/ml protein or ribosomal subunits in H-I buffer and 100 mM Mes buffer (pH = 6.3–7.2). Control experiments were carried out with either only H-I and Mes buffers (mother liquor), or with a protein dissolved in the same mother liquor. In the experiments with inorganic salts, the droplet also contained 0.15 M salt. The reservoirs contained the same mother liquor as the droplet, organic solvent, 6mM β -mercaptoethanol, and, if mentioned, NaCl. ^aPrecipitants: dioxane, b.p. 101°C; ethyl-butanol (EB), b.p. 142°C; ter-butanol, b.p. 83°C; ethan-diol (ED), b.p. 192°C.

^bAbbreviations: s.u. = ribosomal subunits, m.l. = mother liquor, SBA = soybean agglutinin.

^cExamples of typical initial radii and heights are given in Table I.

expected with less volatile solvents. The expansion of the volume of droplets containing ribosomal subunits, in both volatile and less volatile solvent systems, as well as the mild contraction in salt-containing systems (Table IIc), indicate that there is an extra flux of liquid into the droplets. This can be explained by specific interactions of the subunits with water and/or organic solvents. Results of hydrodynamic measurements [25] indicate that the ribosomal subunits of *E. coli* are highly hydrated. From direct determination of the amount of water bound by ribosomes (by successive drying of the subunits), evidence has been obtained that the hydration shell is made up of two components, one of which is bound extremely tightly (Y. Eilam, D. Elson, and D. Danon, unpublished data). Part of the organic solvent may be specifically bound to the subunits rather than being only a solute [26]. The fact that crystals also grow from water-insoluble organic solvents supports this view. As mentioned above, most of the crystals were found on the surface of the drop, where the subunits can interact with the vaporized solvent. This interaction is probably strong enough for the subunits to "emulsify" the insoluble organic solvent, so that more of it can be absorbed into the droplet, again through interactions with subunits on the surface. Structurally this interaction is of much importance as it might even be powerful enough to introduce nucleation centers.

Control of the Drop Size

Initial indications for crystallization were obtained when less volatile solvents were used. This was correlated with the mild expansion of droplet volume produced by these materials, as compared with that produced by the volatile solvents (Table IIa). We therefore searched for conditions that would reduce the amount of expansion, or preferably, cause a decrease in the droplet volume. A method for fine control of the volume of the droplet was thus developed, aimed at reaching the right conditions for crystallization in the early stages of the experiment, before the ribosomal subunits become inactive and lose their ability to crystallize. The method is based on addition of an inert inorganic salt to the reservoir. A typical crystallization experiment (with methanol) was repeated with different amounts of NaCl in the reservoir. The radii and heights of the droplets were measured at intervals of three days. The results of these experiments are shown in Figure 4. Similar behaviour was observed for the other organic solvents (Table IIb).

Sodium chloride (0.5–0.8 M) NaCl is now routinely added to each reservoir upon preparation. A contraction of 6–10% (from the original volume of the droplet) is usually achieved within the first few days, and then the volume remains almost constant for weeks. The total difference between the volume obtained in the presence of salt and in its absence is about 25%. An early addition of salt to the reservoir facilitates crystal growth, for both volatile, and less volatile solvents. Furthermore, the crystals grown with salt present in the reservoir are larger than those grown without salt, and their formation is much more reproducible. However, the presence of salt has no effect if it is added to the reservoir several days after the beginning of the experiment.

Associating lack of crystallization simply with dilution of the subunits due to the droplet expansion is unjustified, since the initial concentration of the subunits could vary over a wide range. It seems that the ability to crystallize is connected with the distribution of the subunits within the droplet during the first days of the experiment. If nucleation is not achieved during this critical period, the subunits in the droplet might lose the right properties for crystallization, since ribosomes kept at 4–6°C gradually

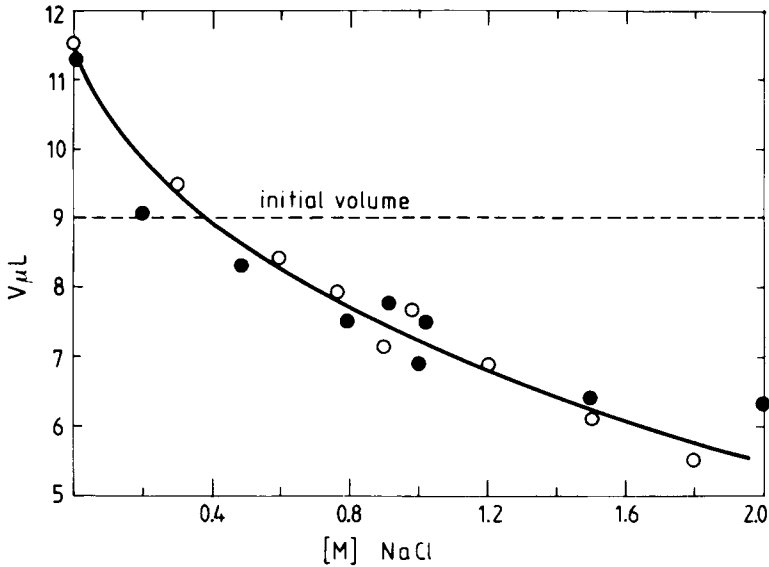

Fig. 4. The volume of the droplet as a function of the concentration of NaCl in the reservoir, observed at the third day (○) and the thirtieth day (●) of the experiment. The contents of the droplet were: 14 mg/ml subunits in H-1 buffer, adjusted to pH 6.6 with 100 mM Mes. The reservoir also contained 15% methanol.

lose their biological activity. A direct visualization of both nucleation and prenucleation stages shows that nucleation occurs within aggregates that are formed within the first few days of the experiment [27].

Crystallization in Capillaries

We were able to improve the quality of the crystals further by employing the same procedure (ie, addition of salt to the reservoir) in X-ray capillaries (Fig. 2). Capillaries have previously been used for growing crystals, although in a different method [28]. Growing crystals directly in X-ray capillaries has the advantage that the crystals need not be transferred for crystallographic studies. It is extremely important to avoid handling the crystals, since even slight changes in the solvent concentration are harmful to the crystals of the ribosomal subunits. The largest and most stable crystals obtained so far were grown in capillaries (Fig. 5a). They reach maximum length of 0.1–0.2 mm and are stable in the X-ray beam for 80–100 hr at 4–6°C. These crystals are still somewhat fragile and not large enough for efficient crystallographic data collection; however, precession patterns of glutaraldehyde cross-linked crystals, although weak, contain data to about 1.0 nm resolution (Fig. 5b).

It is clear that the special geometry of this system helps the production of better crystals. It is not linked to the quantities of the crystallizing material since the volumes used in depression plates (Fig. 3) are larger than in the capillaries, but the quality of crystals produced by the depression plate method is poorer. Evidence has been found for a correlation between the availability of surface area and the degree of nucleation. It was observed both in the hanging drop and in the depression plate techniques that crystals tend to appear on the surface of the drop. It is very probable that this is the location for nucleation. Thus, decreasing the size of the available area for nucleation re-

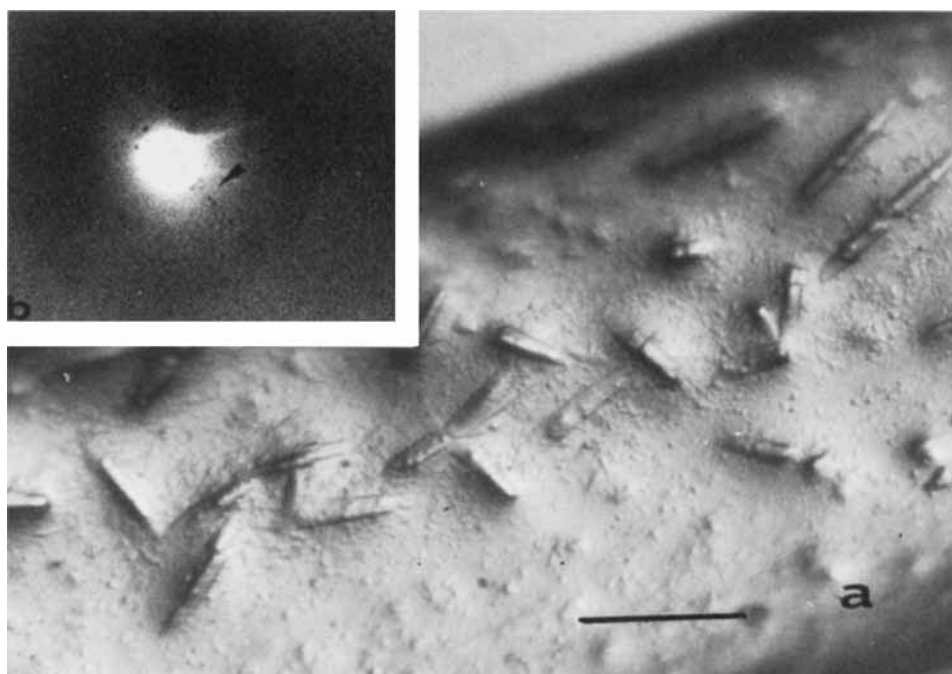

Fig. 5. (a) Crystals grown in capillaries, in 30% methanol, pH 8.7, with 0.5M NaCl in the reservoir (bar length = 0.2mm). (b) 70° precession diffraction pattern (62 hours at 4°C), of a few cross-linked (with 0.2% glutaraldehyde) crystals. One of these crystals was partially oriented, and a small part of its reciprocal lattice, with periodic spacings of 15.4 nm and 26.0 nm, is indicated by an arrow.

sults in production of fewer nuclei, and therefore fewer and larger crystals are obtained. The production of larger crystals can also be linked to the kinetics of diffusion of the organic solvent into the droplet. The relatively large volume of the crystallization chamber (Fig. 2) and the long distance between the reservoir and the crystallization medium cause the initial interaction of the subunits with the organic solvents to occur later than in the other systems. In addition, the time needed to reach equilibrium throughout the column is longer than it takes within a droplet.

As mentioned above, during the process of crystallization a precipitate forms and accumulates in the bottom of the column. Nucleation and precipitation are considered to be competitive processes [29], but the conditions for nucleation and precipitation may be so similar that it is difficult to differentiate between them. Since the formed precipitate may inhibit crystal growth, the spatial separation between the precipitate (bottom of the column) and the site of nucleation and crystal growth (top) is advantageous. In contrast, all the components in the hanging drop are in close proximity to each other, and the precipitate may physically inhibit the growth of the crystals.

CONCLUSIONS

The parameters that control the nucleation and crystal growth are classified into three categories (1) the essential, (2) the important, and (3) the less influential para-

TABLE III. Classification of the Parameters Controlling Crystal Growth*

(a) Essential parameters		
(1) The use of very pure and active subunits.		
(2) Use of organic solvents as crystallization agents.		
(3) Crystallization at low temperature (4–6°C).		
(4) pH range of 4.8–9.5 (best crystals were obtained at pH 6.6–8.8).		
(b) Important parameters		
	For nucleation	For crystal growth
(1) The dynamics of the initial equilibration (a kinetic factor)	++++	+++
(2) The volume and the shape of the droplet or the column (a geometrical factor)	++++	++++
(3) The type* and the concentration of the organic solvent and the exact pH. These parameters vary slightly for each subunit preparation	+	+++
(4) The type of storage buffer and of the mother liquor	+	++
(c) Less influential		
(1) The initial subunit concentration (within the limits of 8–24 mg/ml)		
(2) The age of the subunits (up to 10 years)		
(3) The type of buffer that controls the pH in the droplet (excluding phosphate)		
(4) The presence of spermidine (0.005 M) in the droplet		
(5) Variations in the Mg ²⁺ concentration within the droplet (between 10–30 mM)		

*Suitable organic solvents were: methanol, ethyl-butanol, ethan-diol, EHD, and to a lesser extent: acetone, toluene and MPD.

No crystals have yet been obtained from ethanol, n-butanol, i-propanol, n-pentanol, chloroform, tert-butanol, and glycerol.

meters. The borders between the groups are not well defined. Furthermore, there should be a distinction between “important for nucleation” and “important for growth and production of improved crystals.” A list of these parameters is given in Table III.

In this contribution we have tried to understand the effects of different parameters on crystallization of ribosomal subunits. Although we cannot explain all the observations in a logical fashion, the experimental results have led to a systematic optimization of the growth of crystals of the large ribosomal subunits.

ACKNOWLEDGMENTS

We wish to thank Drs. V.A. Erdmann, B. Tesche, S. Lifson, and Z. Kam for continuous interest and stimulation, Drs. P. Wills, D. Elson, W. Traub, J.L. Sussman, and Mr. S. Lorenz for helpful discussions, and Ms. G. Khavitch for skillful technical assistance.

REFERENCES

1. Brimacombe R, Stöffler G, Wittmann HG: *Ann Rev Biochem* 47:217, 1978.
2. Wool IG: *Ann Rev Biochem* 48:719, 1979.
3. Chambliss G, Craven GR, Davies J, Davies K, Kahan L, Nomura M (eds): "Ribosomes: Structure, Function and Genetics." Baltimore: University Park Press, 1979.
4. Wittmann HG: *Ann Rev Biochem* 15:155, 1982.
5. Noller HF: In Chambliss G et al (eds): "Ribosomes: Structure, Function and Genetics." Baltimore: University Park Press, 1979, pp 3-22.
6. Stöffler G, Bald R, Kastner B, Lührmann R, Stöffler-Meilicke M, Tischendorf G, Tesche B: In Chambliss G et al (eds): "Ribosomes: Structure, Function and Genetics." Baltimore: University Park Press, 1979, pp 171-206.
7. Lake JA: In Chambliss G et al (eds): "Ribosomes: Structure, Function and Genetics." Baltimore: University Park Press, 1979, pp 207-236.
8. Moore PB: In Chambliss G et al (eds): "Ribosomes: Structure, Function and Genetics." Baltimore: University Park Press, 1979, pp 111-134.
9. Traut RR, Lambert JM, Boileau G, Kenny JW: In Chambliss G et al (eds): "Ribosomes: Structure, Function and Genetics." Baltimore: University Park Press, 1979, pp 89-110.
10. Cantor CR: In Nomura M, Tissieres A, Lengyel P (eds): "Ribosomes." Long Island, NY: Cold Spring Harbor Lab, 1974, pp 587-599.
11. Nomura M, Held WA: In Nomura M, Tissieres A, Lengyel P (eds): "Ribosomes." Long Island, NY: 1974, Cold Spring Harbor Lab, pp 193-223.
12. Nierhaus KH: In Chambliss G, et al. (eds): "Ribosomes: Structure, Function and Genetics." Baltimore: University Park Press, 1979, pp 267-296.
13. Finch JT, Brown RS, Rhodes D, Richmond T, Rushton B, Lutter LC, Klug A: *J Mol Biol* 145:755, 1981.
14. Abad-Zapatero C, Abdel-Meguid SS, Johnson JE, Leslie AGW, Rayment I, Rossmann MG, Suck D, Tsukihar T: *Nature* 286:33, 1980.
15. Harrison SC, Olson AJ, Schutt CE, Winkler FK, Bricongne G: *Nature* 276:368, 1978.
16. Wilson IA, Skehel JJ, Wiley DC: *Nature* 289:336, 1980.
17. Kühlbrandt W, Unwin PNT: In W Baumeister, W Vogell (eds): "Electron Microscopy at Molecular Dimensions." Berlin, Heidelberg, New York: Springer-Verlag, 1980, pp 108-116.
18. Barbieri M: *J Supramol Struct* 10:349, 1979.
19. O'Brien L, Shelley K, Towfighi J, McPherson A: *Proc Natl Acad Sci USA* 77:2260, 1980.
20. Yonath A, Müssig J, Tesche B, Lorenz S, Erdmann VA, Wittmann HG: *Biochem Inter* 1:428, 1980.
21. Leonard KR, Arad T, Tesche B, Erdmann VA, Wittmann HG, Yonath A: 7th Annual EMBO Symposium, Heidelberg (abstr), 1981.
22. Davies DR, Segal DM: In WB Jacoby (ed): "Methods in Enzymology." New York: Academic Press, Vol. 22, 1972, pp 266-269.
23. McPherson A: In "Methods of Biochemical Analysis." New York: Academic Press, vol 23, 1976, pp 249-345.
24. Blundell TL, Johnson LN: "Protein Crystallography." New York: Academic Press, 1976.
25. Van Holde KE, Hill WE: In Nomura M, Tissieres A, Lengyel P (eds): "Ribosomes" Long Island, NY: Cold Spring Harbor Lab., 1974, pp 53-92.
26. Miskin R, Zamir A, Elson D: *J Mol Biol* 54:355, 1970.
27. Yonath A, Khavitch G, Müssig J, Tesche B, Lorenz S, Erdmann VA, Wittmann HG: *Biochem Internat* (in press).
28. Fridborg K, Hjerten S, Høglund S, Liljas A, Lundberg KS, Oxelfelt P, Philipson L, Strandberg B: *Proc Natl Acad Sci USA* 54:513, 1965.
29. Kam Z, Shore HB, Feher G: *J Mol Biol* 123:539, 1978.